

# IO-PT4 I/O Expansion Module

4 PT100 Inputs (-50 to 460°C)

The IO-PT4 is an I/O expansion module that can be used in conjunction with specific Unitronics OPLC controllers.

The module offers 4 PT100 inputs for temperature measurement.

The interface between the module and the OPLC is provided by an adapter.

The module may either be snap-mounted on a DIN rail, or screw-mounted onto a mounting plate.

Component identification	
1	Module-to-module connector
2	Status indicators
3	Input connection points, PT2 & PT3
4	Module-to-module connector port
5	Input connection points, PT0 & PT1

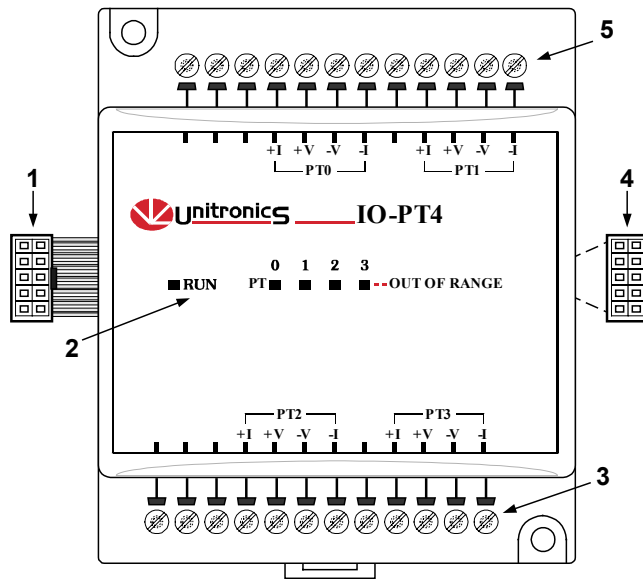

## User safety and equipment protection guidelines

This document is intended to aid trained and competent personnel in the installation of this equipment as defined by the European directives for machinery, low voltage and EMC. Only a technician or engineer trained in the local and national electrical standards should perform tasks associated with the electrical wiring of this device.

- Under no circumstances will Unitronics be liable or responsible for any consequential damage that may arise as a result of installation or use of this equipment, and is not responsible for problems resulting from improper or irresponsible use of this device.
- All examples and diagrams shown in the manual are intended to aid understanding. They do not guarantee operation.
- Unitronics accepts no responsibility for actual use of this product based on these examples.
- Only qualified service personnel should open this device or carry out repairs.
- Please dispose of this product in accordance with local and national standards and regulations.



- Check the user program before running it.
- Do not attempt to use this device with voltage exceeding permissible levels.
- Install an external circuit breaker and take appropriate safety measures against short-circuiting in external wiring.



- Failure to comply with appropriate safety guidelines can result in severe personal injury or property damage. Always exercise proper caution when working with electrical equipment.

**Mounting the Module**

**Mounting Considerations**

- Do not install in areas with: excessive or conductive dust, corrosive or flammable gas, moisture or rain, excessive heat, regular impact shocks or excessive vibration.
- Provide proper ventilation by leaving a minimum space of 10mm between the top and bottom edges of the device and the enclosure walls.
- Do not place in water or let water leak onto the unit.
- Do not allow debris to fall inside the unit during installation.

**DIN-rail mounting**

Snap the device onto the DIN rail as shown below; the module will be squarely situated on the DIN rail.

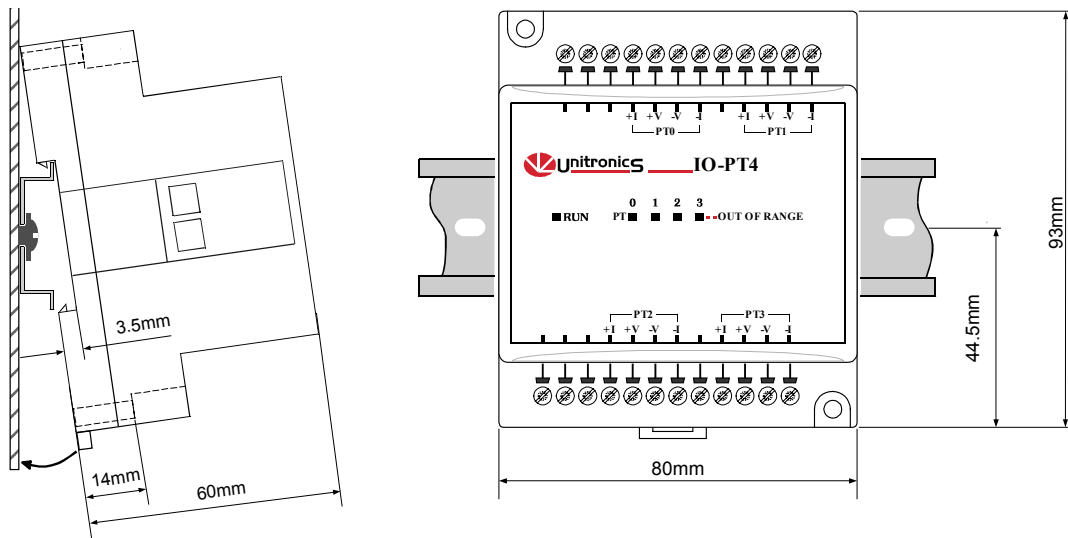

**Screw-Mounting**

The figure on the next page is drawn to scale. It may be used as a guide for screw-mounting the module. Mounting screw type: either M3 or NC6-32.

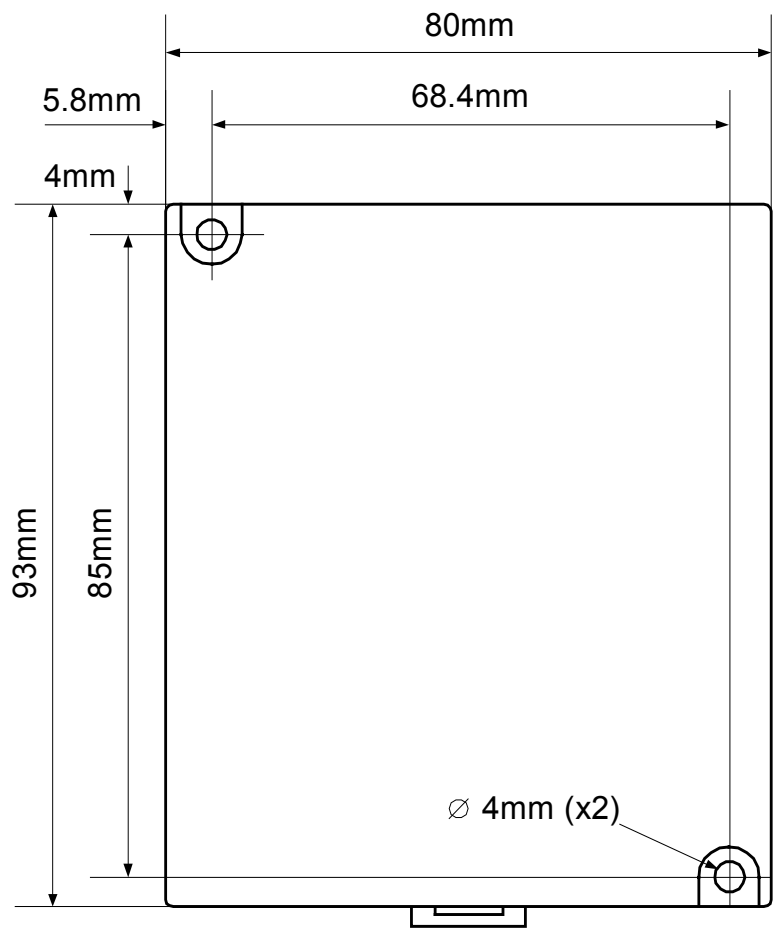

## Connecting Expansion Modules

An adapter provides the interface between the OPLC and an expansion module. To connect the I/O module to the adapter or to another module:

- 1 Push the module-to-module connector into the port located on the right side of the device.

Note that there is a protective cap provided with the adapter. This cap covers the port of the **final** I/O module in the system.



- To avoid damaging the system, do not connect or disconnect the device when the power is on.

Component identification	
1	Module-to-module connector
2	Protective cap

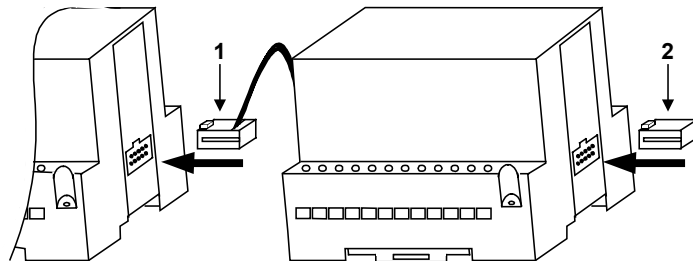

## Wiring

### Wire Size

Use 26-12 AWG wire (0.13 mm<sup>2</sup>–3.31 mm<sup>2</sup>) for all wiring purposes.

### Wiring Considerations

- Do not use tin, solder or any other substance on the stripped wire that might cause the wire strand to break.
- We recommend that you use crimp terminals for wiring.
- Install at maximum distance from high-voltage cables and power equipment.

### General Wiring Procedures

- 1 Strip the wire to a length of 7±0.5mm (0.250–0.300 inches).
- 2 Unscrew the terminal to its widest position before inserting a wire.
- 3 Insert the wire completely into the terminal to ensure that a proper connection can be made.
- 4 Tighten enough to keep the wire from pulling free.

To avoid damaging the wire, do not exceed a maximum torque of 0.5 N·m (5 kgf·m).



- Do not touch live wires.
- Double-check all the wiring before turning on the power supply.

**Input Wiring**

- Shields should be connected at the signal source.

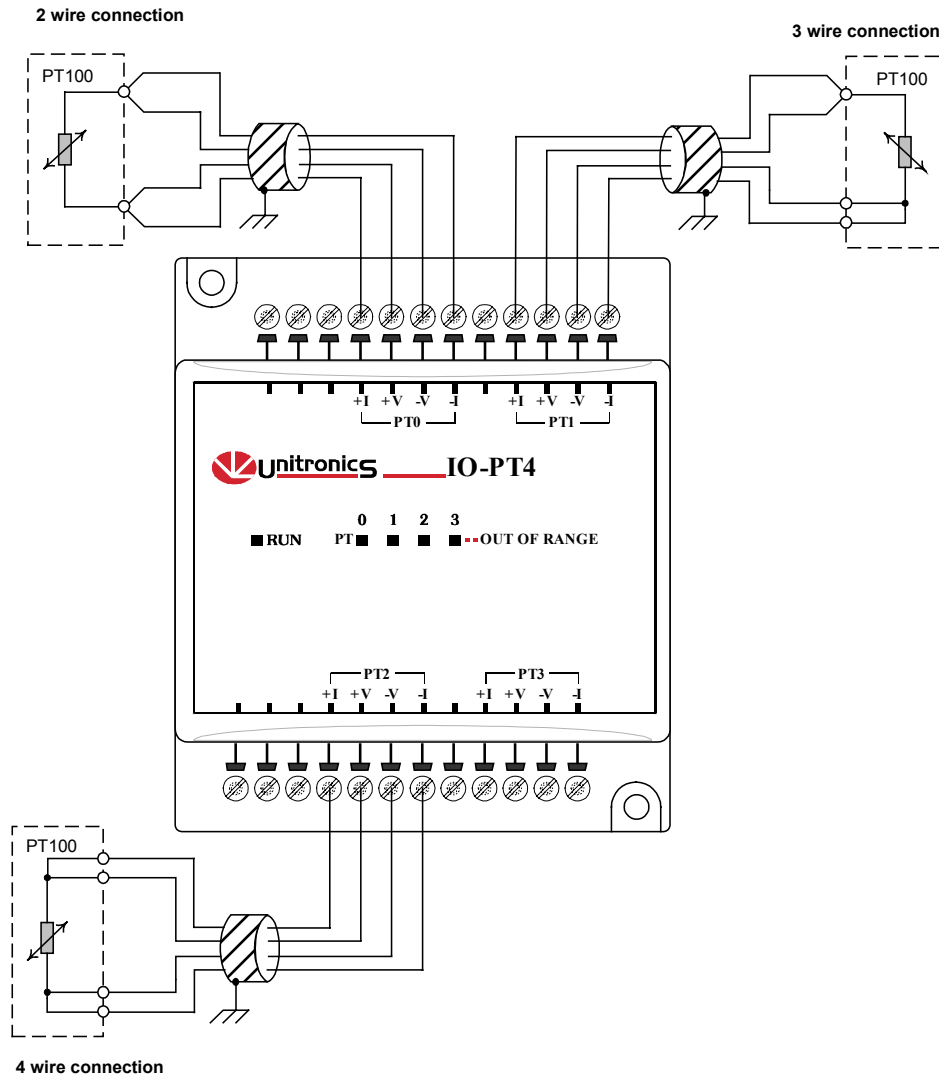

**IO-PT4 Technical Specifications**

Max. current consumption	35mA maximum from the adapter's 5VDC
Typical power consumption	0.09W @ 5VDC
Status indicator (RUN)	Green LED: —Lit when a communication link is established between module and OPLC. —Blinks when the communication link fails.

**Analog Inputs**

Number of inputs	4
Input type	PT100
Input range	-50° to 460°C
Isolation	None
Resolution	12-bit (4096 units)
Measurement resolution	±0.1°C. See Note 1.
Conversion method	Successive approximation
Conversion time	40msec
Input impedance	10MΩ minimum
Auxiliary current for PT100	1.9mA
Linearity error	±0.25°C (±0.05%)
Temperature accuracy	±0.4°C
Status indicators (OUT OF RANGE)	Red LEDs—Lit when the corresponding input measures an analog value (temperature) outside of the permissible range. See Note 2.
Connection options	2,3 or 4 wires

**Environmental**

	IP20
Operating temperature	0° to 50°C
Storage temperature	-20° to 60°C
Relative Humidity (RH)	5% to 95% (non-condensing)
Dimensions (WxHxD)	80mm x 93mm x 60mm
Weight	140.3g (4.94oz.)
Mounting	Either onto a 35mm DIN-rail or screw-mounted.

**Notes:**

- The input analog value represents the temperature value as follows:  
Analog value-262                      Actual measured temperature: 26.2°C
- The temperature values can also indicate certain faults as shown in the table below.

Value	Possible Cause
-1000°C	* Input temperature is out of the permissible range (under -50°C) * -I signal is not connected * Sensor is short-circuited
1000°C	* Input temperature is out of the permissible range (over 460°C) * Sensor is not connected to input * +I or +V signals are not connected * -I and -V signals are not connected

## Addressing I/Os on M90 Expansion Modules

Inputs and outputs located on I/O expansion modules that are connected into an M90 OPLC are assigned addresses that comprise a letter and a number. The letter indicates whether the I/O is an input (I) or an output (O). The number indicates the I/O's location in the system. This number relates to both the position of the expansion module in the system, and to the position of the I/O on that module.

Expansion modules are numbered from 0-7 as shown in the figure below.

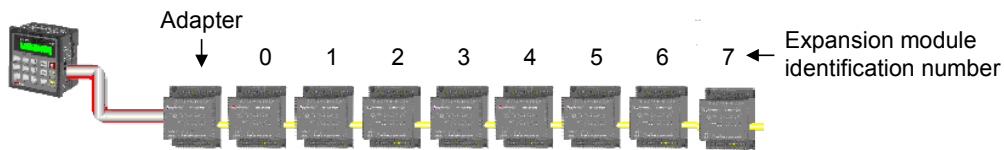

The formula below is used to assign addresses for I/O modules used in conjunction with the M90 OPLC. X is the number representing a specific module's location (0-7). Y is the number of the input or output on that specific module (0-15).

The number that represents the I/O's location is equal to:

$$32 + x \cdot 16 + y$$

Examples

- Input #3, located on expansion module #2 in the system, will be addressed as I 67,  
 $67 = 32 + 2 \cdot 16 + 3$
- Output #4, located on expansion module #3 in the system, will be addressed as O 84,  
 $84 = 32 + 3 \cdot 16 + 4$ .

EX90-DI8-RO8 is a stand-alone I/O module. Even if it is the only module in the configuration, the EX90-DI8-RO8 is always assigned the number 7.

Its I/Os are addressed accordingly.

Example

- Input #5, located on an EX90-DI8-RO8 connected to an M90 OPLC will be addressed as I 149,  $149 = 32 + 7 \cdot 16 + 5$

# 8 Convenient I/O Modules

	Digital I/O (transistor)			Digital I/O (relay)			Analog I/O	PT 100
	IO-DI8-T08	IO-DI16	IO-T016	IO-DI8-RO4	IO-RO8	EX90-DI8-RO8*		
Digital inputs (24VDC)	8 pnp/npn (source/sink)	16 pnp/npn (source/sink)	—	8 pnp/npn (source/sink)	—	8 pnp (source)	—	—
Analog inputs	—	—	—	—	—	—	4 inputs 0-10V, 0-20mA, 4-20mA	4 PT100 -50° to 460°C
Analog input resolution	—	—	—	—	—	—	12 bit	12 bit
Digital outputs	8 pnp (source)	—	16 pnp (source)	4 relay outputs	8 relay outputs	8 relay outputs	—	—
Analog outputs	—	—	—	—	—	—	2 outputs ±10V, 0-20mA, 4-20mA	—
Analog output resolution	—	—	—	—	—	—	12 bit + sign	—
High-speed counter/ Frequency measurement	One	One	—	One	—	One	—	—

\* Stand-alone module. Other modules are used in conjunction with the EX-A1 adapter

*To order the expansion module that best fits your system, contact your local distributor.  
For a list of Unitronics distributors, check our website: <http://www.unitronic.com/contact.htm>*